

KATALÓG NÁHRADNÝCH DIELOV
SV18RA

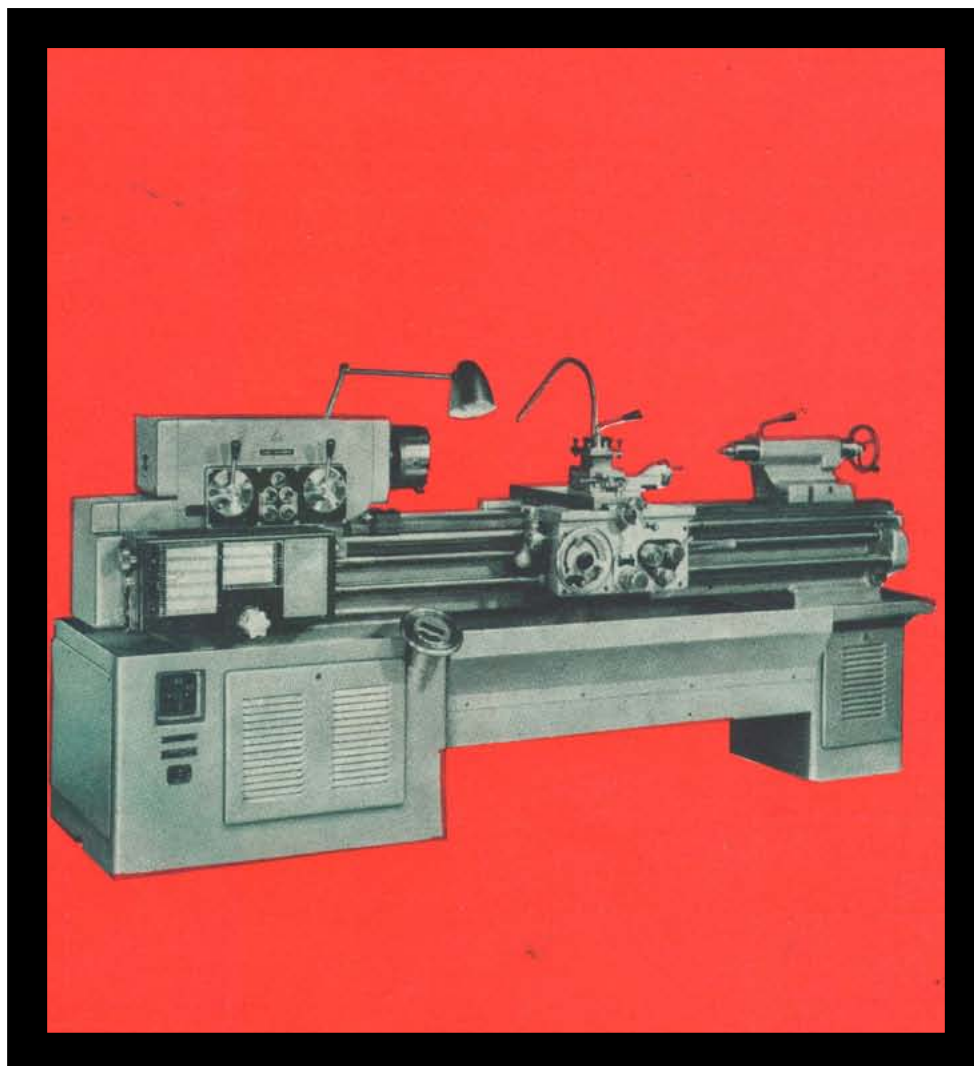

Vreteník 901000	4
Koník 907000	9
Lůžko 910000	12
Suportová skriňa 904000, 905000	15
Sane, suporty 906000	20
Nortonová skriňa 903000	24
Rýchlostná skriňa 902000	31
Štítky	36

PRESNÝ NÁSTROJOVÝ HROTOVÝ SÚSTRUH SV18RA

V SNAHE O ZPRESNENIE
A ZJEDNODUŠENIE
OBJEDNÁVOK NÁHRADNÝCH
DIELOV PRE PRESNÝ
NASTROJARSKY HROTOVÝ
SÚSTRUH SV 18 RA VÁM
PREDKLADÁME TENTO
KATALÓG NÁHRADNÝCH
DIELOV, PODĽA KTORÉHO
MÔŽETE NAHRADNÉ
DIELY V OBJEDNÁVKE PRESNE
OZNAČIŤ. NÁHRADNÉ DIELY SÚ
V KATALÓGU ROZDELENÉ DO
SKUPÍN, KTORÉ ODPOVEDAJÚ
KONŠTRUKČNÝM ZOSTAVÁM
STROJA. ÚDAJE OBSAHUJÚ
NÁZOV NÁHRADNÉHO
DIELU, PORADOVÉ ČÍSLO,
ČÍSLO VÝKRESU, BEŽNÉ ČÍSLO,
VÁKU A POČET KUSOV.

V OBJEDNÁVKE
UVÁDZAJTE LÁSKAVO PODĽA
TOHTO PRÍKLADU:

VÝROBNÉ ČÍSLO STROJA:
VRETENÍK – PORADOVÉ ČÍSLO
26 – ČÍSLO VÝKRESU 230538 –
BEŽNÉ ČÍSLO 901040 – LOŽISKO
PREDNÉ – 3 KUSY

ÚDAJE I VYOBRAZENIE
SÚ V PODROBNOSTIACH
NEZÁVÄZNÉ.



VRETENÍK 901000

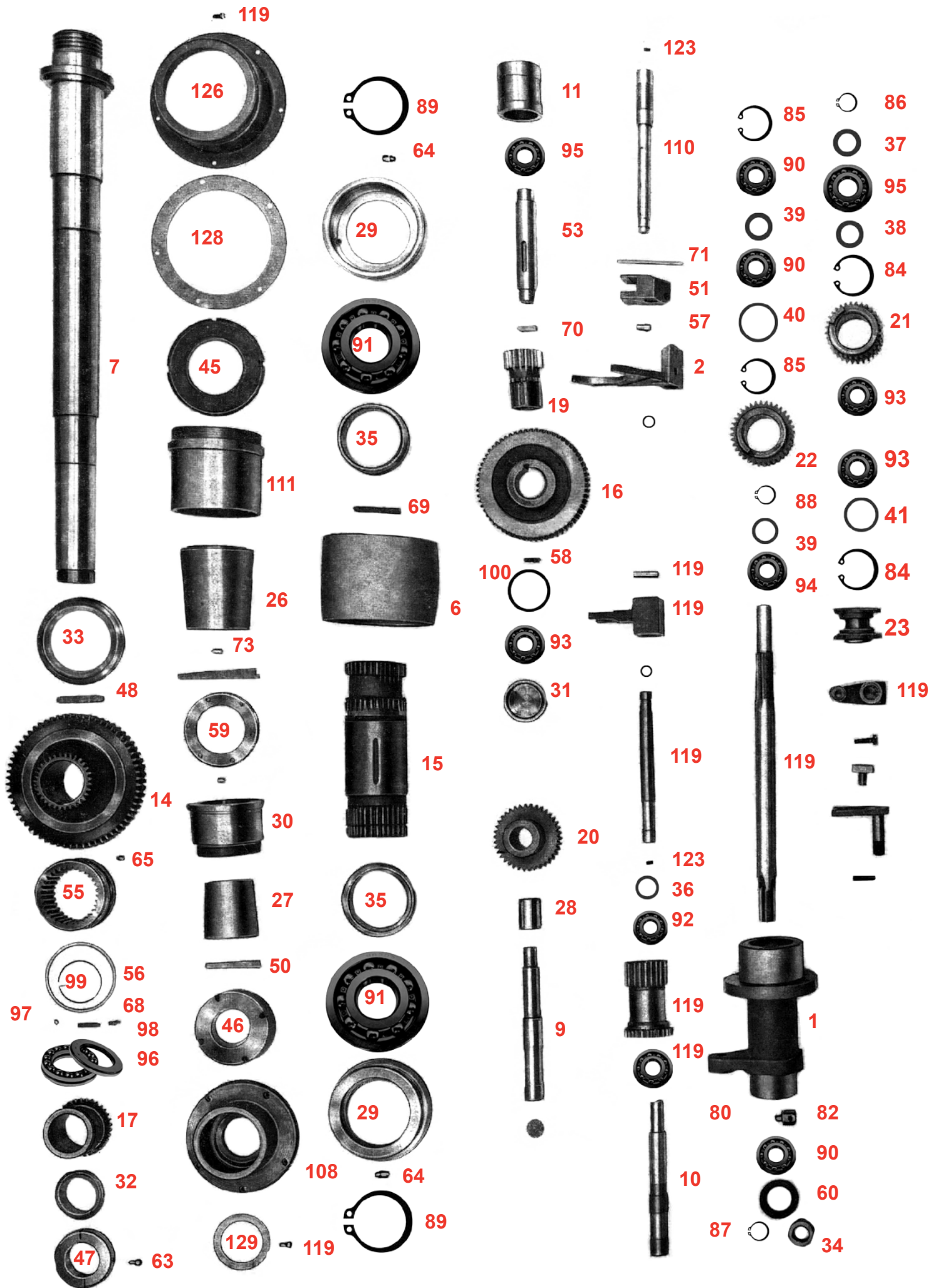

Vreteník 901000

1	2	3	4	5	6	1	2	3	4	5	6
Poradové číslo	Číslo výkresu	Bežné číslo	Názov	Váha / ks (kg)	Počet ks						
						26	230538	901040	Ložisko - predné	2.72	1
						27	230255	901041	Ložisko - zadné	1.08	1
						28	230256	901042	Puzdro	0.16	1
1	030390	901002	Konzola	6.36	1	29	230257	901043	Puzdro ložiska	1.24	2
2	050401	901003	Presúvač	0.8	1	30	250542	901045	Puzdro ložiska - zadné	1.58	1
3	050401	901003	Presúvač	0.94	1	31	251156	901046	Puzdro ložiska	0.26	1
4	1744	901008	Spodné veko	1.85	1	32	260672	901051	Krúžok odstrekový	0.26	1
5	080269	901014	Veko presúvača	6.36	1	33	260673	901052	Krúžok odstrekový	0.32	1
6	090044	901017	Remenica	5.16	1	34	261183	901050	Koncový krúžok	0.1	1
7	10210	901018	Vreteno	9.98	1	35	260904	901049	Krúžok rozperný	0.48	1
8	110510	901019	Hriadel IV	2.17	1	36	260675	901054	Krúžok rozperný	0.02	1
9	110024	901020	Hriadel III	0.95	1	37	260676	901055	Krúžok rozperný	0.01	1
10	10025	901021	Hriadel V	0.88	1	38	260677	901054	Krúžok rozperný	0.022	1
11	VK 1251	901024	Zátka	1.5	1	39	260678	901057	Krúžok rozperný	0.03	2
12	140384	901025	Čap páky - spojky	6.36	1	40	260679	901058	Krúžok	0.02	1
13	140385	901026	Čap klzný	0.09	1	41	260680	901059	Podložka	0.002	1
14	161353	901028	Ozubené kolo	10.88	1	42	330168	901061	Páka spojky	0.35	1
15	161348	901029	Ozubené dvojkolo	4.14	1	43	360168	901063	Náboj ručnej páky	0.4	2
16	161351	901030	Ozubené kolo	9.4	1	44	412395	901065	Skrutka trubková	0.05	2
17	160756	901031	Ozubené kolo	0.65	1	45	450487	901068	Matica - predná	0.94	1
18	160757	901032	Ozubené dvojkolo	4.2	1	46	VK 2335	901069	Skrutka - zadná	1.7	1
19	161352	901033	Ozubené kolo	0.6	1	47	450239	901070	Skrutka stavaná	0.36	1
20	160759	901034	Ozubené kolo - predloha	0.76	1	48	470228	901071	Pero	0.04	1
21	106760	901035	Kolo spojky - pravé	0.88	1	49	540870	901076	Vložka puzdra	0.2	1
22	160761	901036	Kolo spojky - ľavé	0.6	1	50	540871	901077	Presúvač	0.04	1
23	210102	901037	Spojka zubová	0.51	1	51	050402	901087	Presúvač	0.46	1
24	210479	901038	Kotúč presúvača	0.64	1	52	VK 1314	901088	Veko presúvača	1.5	1
25	253989	901039	Kotúč presúvača - zadný	0.38	1						

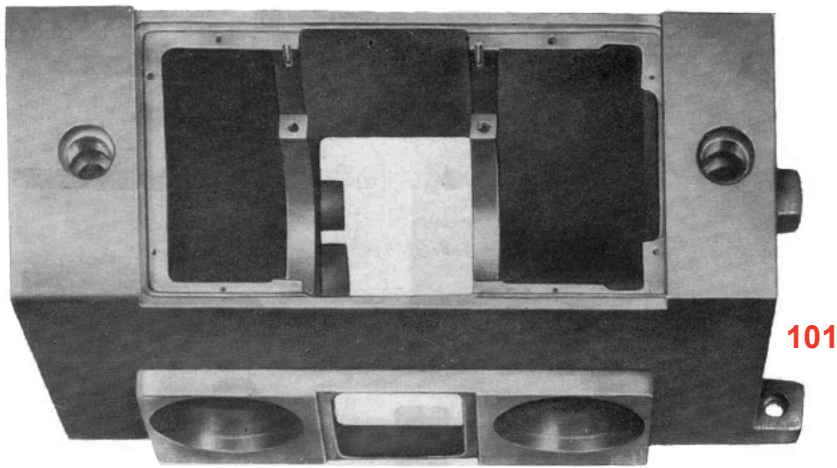
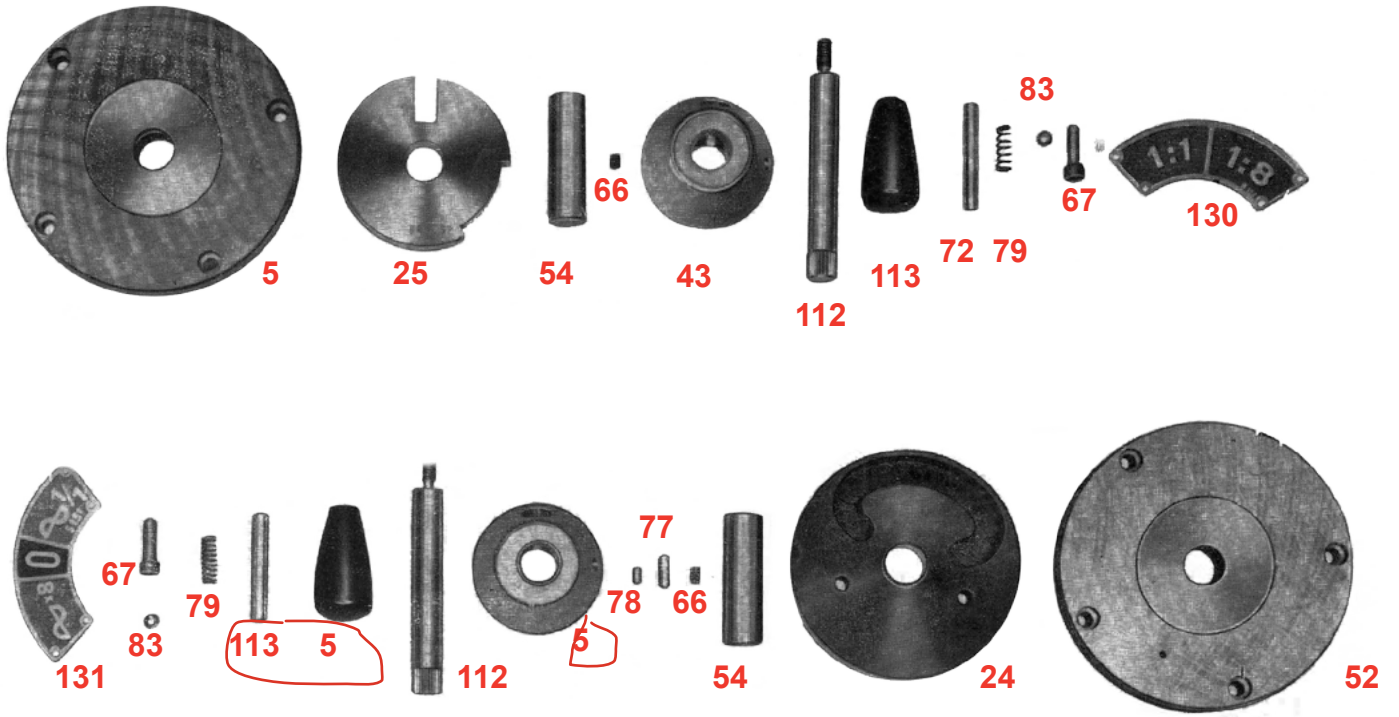

108

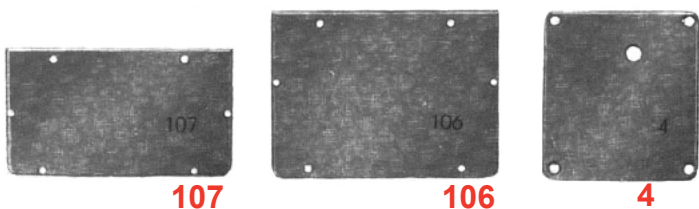
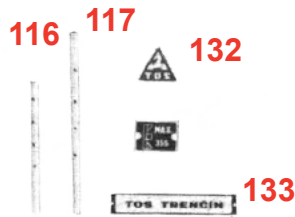
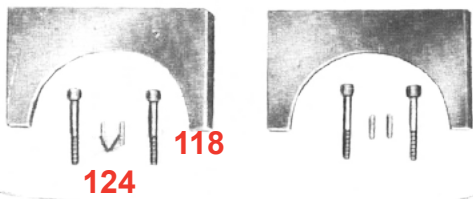
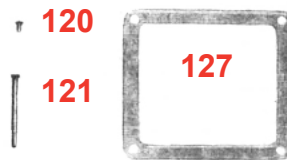
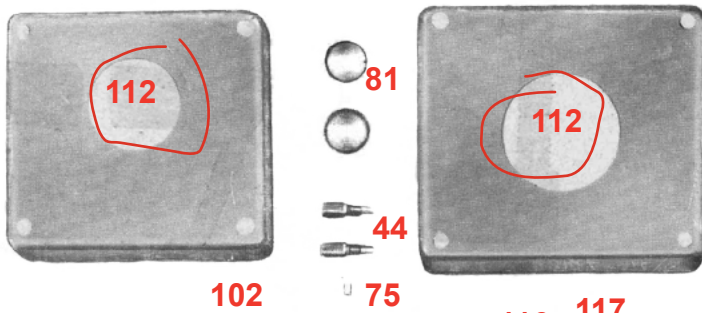
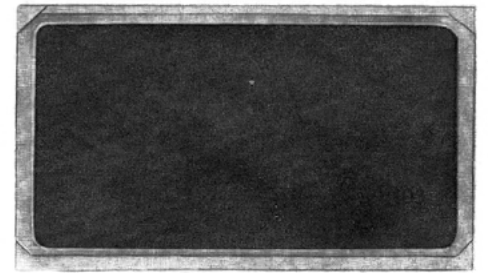

53	110591	901090	Hriadeľ	0.85	1
54	142114	901091	Čap	0.15	2
55	161349	901092	Spojka zubová	0.8	1
56	261338	901095	Krúžok	0.09	1
57	901097	901097	Čap presúvača	0.02	1
58	410904	901098	Skrutka	0.025	1
59	450486	901099	Matica vnútorná	0.35	1
60	UN 029401	-	Guffero	0.015	1
79	901250	901250	Pružina	0.01	1
81	ČSN 028686	901253	Olejoznak M24x1.5	0.03	2
82	50410146	901254	Mazacia hlavička	0.05	1
101	50030108	901401	Teleso	108	1
102	5021102	901402	Strmeň	1.30	2
103	5006080	901405	Veko - vrchné	7.50	1
125		901455	Remeň plochýww	1.30	1

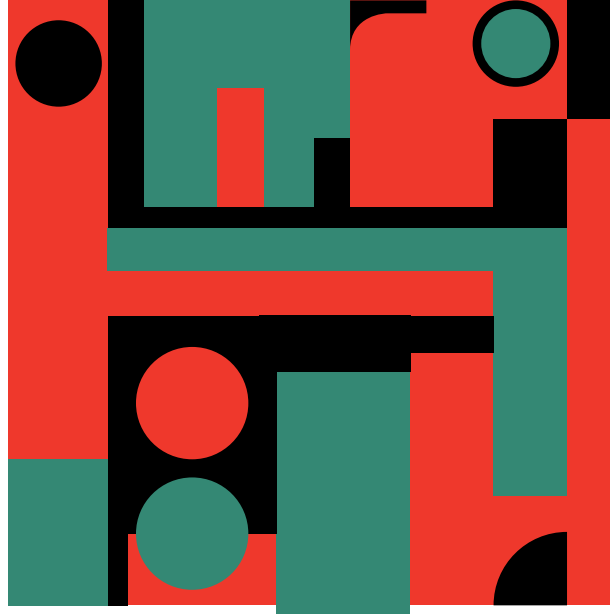

KONÍK 907000

1	2	3	4	5	6
Poradové číslo	Číslo výkresu	Bežné číslo	Názov	Váha / ks (kg)	Počet ks
1	5003112	907151	Koník-zostava	37.00	1
2	2030338	907002	Doska koníka	13.30	1
3	VK 1315	907005	Pinola	17.70	1
4a	400053	907020	Skrutka a matica pinoly koníka bez nóniusu	0.90	1
4b		907199	Skrutka a matica pinoly koníka s nóniusom	1.00	1
5					
6	3361095	907111	Koleso	0.75	1
7	Sy220142	907007	Hriadel s výstredníkom	0.79	1
8	VK 1633	907004	Oko výstredníka	1.20	1
9	305191	907152	Strmeň	2.00	1
10	Sy440051	907026	Matica	1.00	1
11	45030325	907156	Páka	0.60	1
12	250528	907013	Puzdro skrutky	0.44	1
13	260650	907014	Unášač deliaceho krúžku	0.38	1
14	260651	907015	Krúžok rozperný	0.32	1
15	VK 1666	907012	Trň	0.89	1
16	250525-26	907011-10	Čelusť horná + spodná	0.50	2
17	280037	907016	Nónius metrický 0-4 mm	0.10	1
18		907022	Skrutka krátka	0.08	1
19		907023	Skrutka dlhá	0.10	1
20		900010	Čap + rukoväť Ø10	0.10	1





LÔŽKO 910000

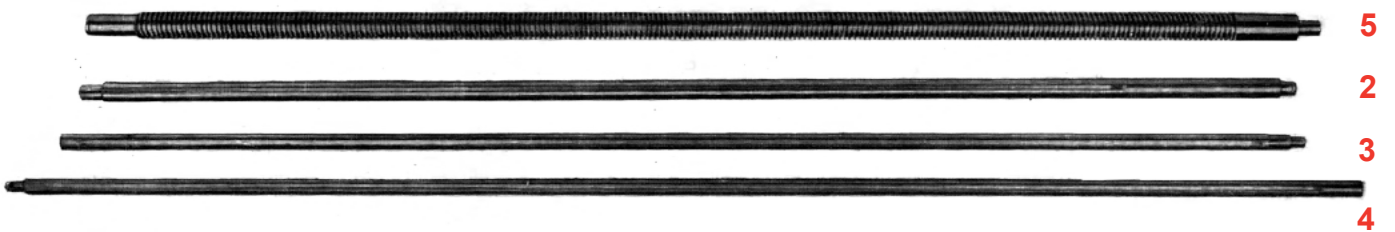
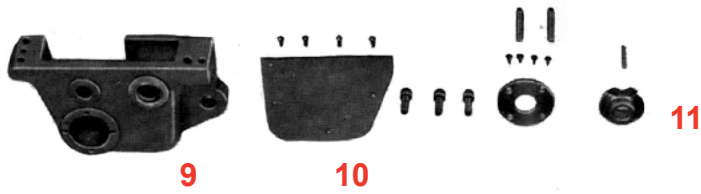
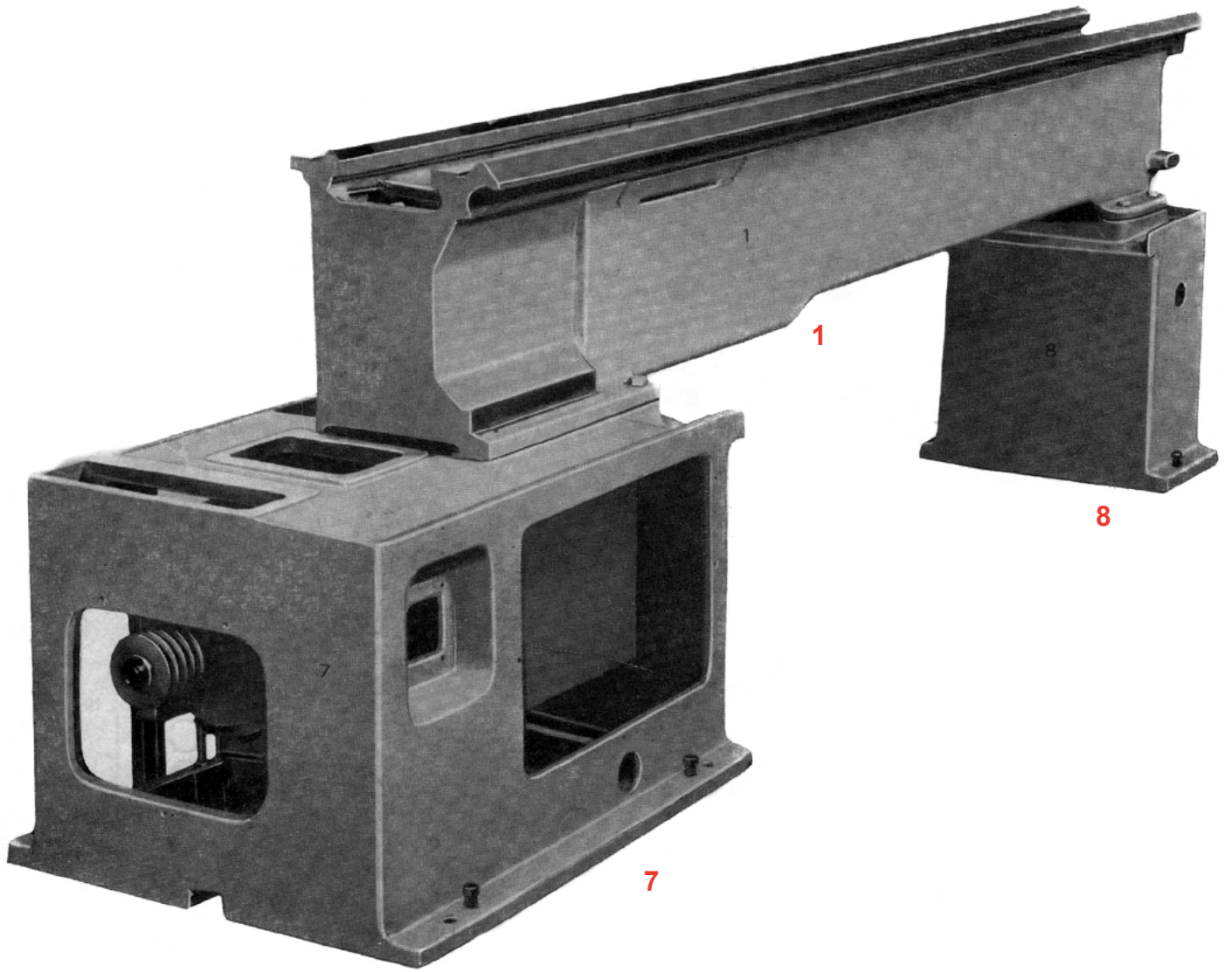

1	2	3	4	5	6	1	2	3	4	5	6
Poradové číslo	Číslo výkresu	Bežné číslo	Názov	Váha / ks (kg)	Počet ks						
Platí pre točnú dĺžku 500 mm						Platí pre točnú dĺžku 1250 mm					
1	5001167	910004	Lôžko 500	6.2	6.2	1	5001071	912184	Lôžko 1250	487	1
2	5011741	910006	Ťažný hriadeľ	4.9	1	2	110304	92140	Ťažný hriadeľ	5.5	1
3	5011742	910007	Vypínacia tyč	4.2	1	3	5011431	912188	Vypínacia tyč	5.5	1
4	5011743	910008	Hriadeľ spojky	3.9	1	4	5011416	912187	Hriadeľ spojky	5.6	1
5	5038130	910010	Vodiaca skrutka	4	0.07	5	400381	912144	Vodiaca skrutka	12.46	1
6	190032	911143	Hrebeň	2.73	1	6	190032	192143	Hrebeň	2.73	2
7	50001141	908629	Predná noha	290	1	Spojovacie dielce					
8	5001073	908631	Zadná noha	135	1	12	VK 2261	902182	Rozperná skrutka vonkajšia	0.4	1
9	VK2090	908633	Koncové ložisko	2.8	1	13	VK 2260	902181	Rozperná skrutka vnútorná	0.3	1
10	5053152	908648	Kryt zadného ložiska	0.28	1	14	142194	902030	Čap s okom	0.9	1
11	5022143	908646	Vačka	2.8	1	15	410442	902061	Skrutka s okom	0.9	1
Platí pre točnú dĺžku 750 mm						16	45011427	902267a	Mechanizmus brzdy	0.35	1
1	2001069	910184	Lôžko 750	370	1	17	142208	902027	Čap vonkajší	0.72	1
2	50110359	910140	Ťažný hriadeľ	6.5	1	18	142207	902028	Čap vnútorný	0.52	1
3	50111429	910188	Vypínacia tyč	4.5	1						
4	5011414	910187	Hriadeľ spojky	4.6	1						
5	400379	910144	Vodiaca skrutka	8.9	1						
6	190035	190143	Hrebeň	1.82	2						
Platí pre točnú dĺžku 1000 mm											
1	5001070	911184	Lôžko 1000	409	1						
2	110301	911140	Ťažný hriadeľ	6.46	1						
3	5011430	911188	Vypínacia tyč	5	1						
4	110302	911141	Hriadeľ spojky	5.1	1						
5	400380	911144	Vodiaca skrutka	10	1						



SUPPORTOVÁ SKRIŇA 904000, 905000

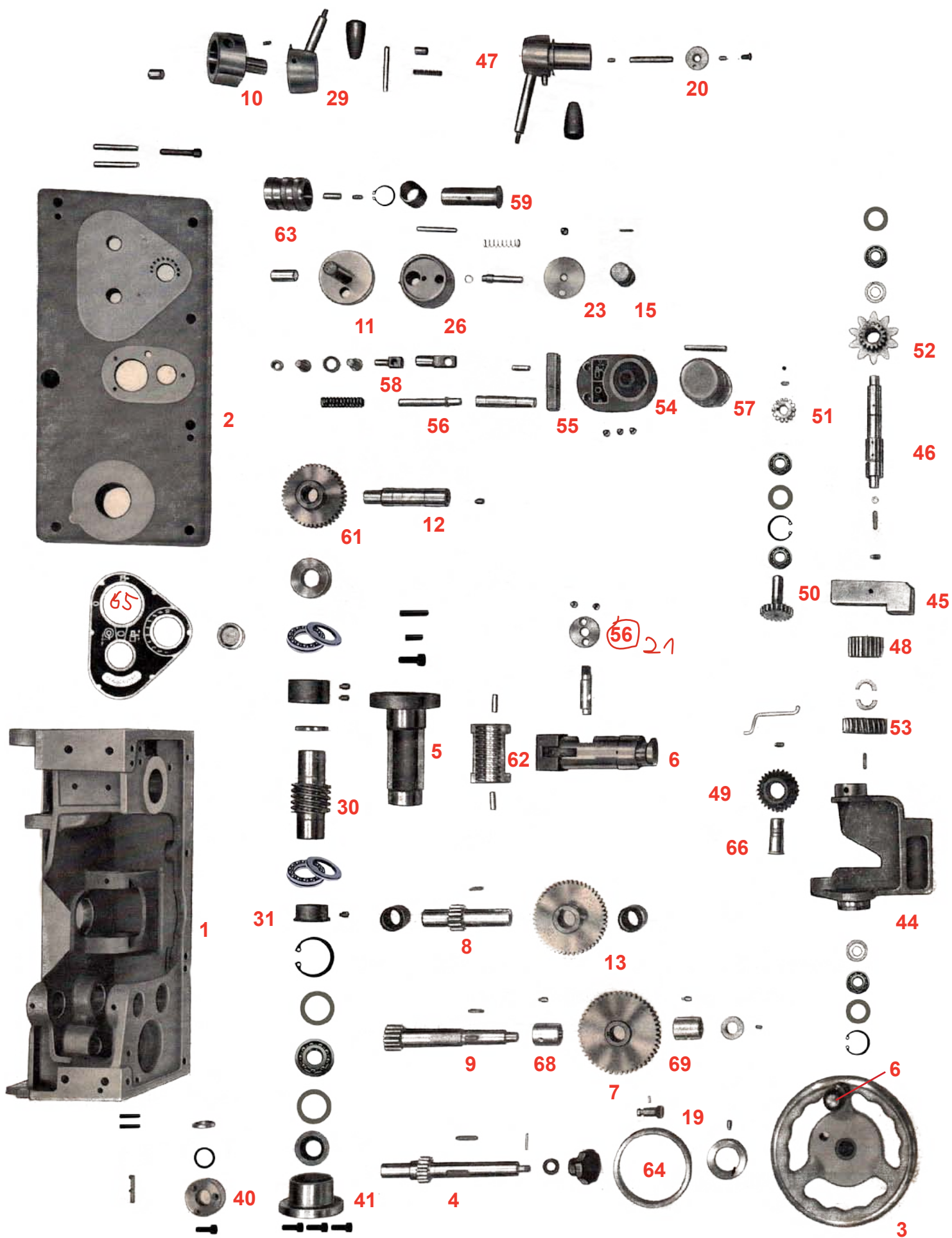

Suportová skriňa 90400, 905000

1	2	3	4	5	6	1	2	3	4	5	6
Poradové číslo	Číslo výkresu	Bežné číslo	Názov	Váha / ks (kg)	Počet ks						
						26	360241	904072	Náboj páky	0.88	1
						27	360281	904508	Aretačný krúžok	0.30	1
						28	360134	904063	Náboj páky	0.74	1
1	11395	904001	Teleso skrine	33.00	1	29	360131	904060	Náboj páky	0.63	1
2	30346	904022	Veko	11.67	1	30	200035	904025	Šnek	0.63	1
3	360130	904059	Ručné kolo	3.70	1	31	230199	904028	Puzdro	0.38	1
4	VK 2291	904018	Hriadeľ - pastorok	0.50	2	32	561150	904284	Mazacia trubka	0.02	1
5	VK 1567	904500	Puzdro operné	1.80	1	33	561149	904283	Mazacia trubka	0.02	1
6	140290	904011	Čap zapínací	1.70	1	34	5813732	904286	Mazacia trubka	0.001	1
7	160712	904021	Ozubené kolo 49 z	1.02	1	35	5813735	904289	Mazacia trubka	0.002	1
8	160711	904020	Hriadeľ - pastorok	0.46	1	36	58113736	904290	Mazacia trubka	0.002	1
9	160710	904019	Hriadeľ - pastorok	0.68	1	37	5813733	904287	Mazacia trubka	0.002	1
10	140291	904012	Čap páky	0.80	1	38	5813737	904291	Mazacia trubka	0.002	1
11	253041	904013	Kotúč čapu	0.62	1	39	5813738	904292	Mazacia trubka	0.002	1
12	140293	904014	Čap s excentrom	0.59	1	40	83373	904305	Veko	0.22	1
13	160714	904023	Ozubené kolo	0.52	1	41	254525	907307	Puzdro	0.30	1
14	30347	904007	Teleso čerpadla	0.46	1	42	VK 1569	904502	Náboj páky	0.44	1
15	161348	904034	Vložka	0.10	1	43	361012	904514	Náboj spojkovvej páky kompletý	1.50	1
16	310076	904046	Piest	0.10	1	44	30348	905001	Páka	1.00	1
17	310078	904048	Sedlo výtlačné	0.05	1	45	50296	905004	Rameno	0.86	1
18	310079	904049	Nátrubok	0.01	3	46	110434	904010	Hriadeľ	0.38	1
19	220113	904050	Čap s excentrom	0.03	1	47	140295	904063	Páka reverzu	0.6	2
20	320448	904051	Podložka	0.02	1	48	160715	905020	Ozubená spojka	0.19	1
21	320259	904052	Príložka	0.07	1	49	160716	905021	Ozubená spojka	0.21	1
22	314579	904054	Rozdelovač oleja	0.22	1	50	161059	905022	Ozubené kolo	0.19	1
23	320461	904057	Príložka	0.01	1	51	161060	905023	Ozubené kolo	0.16	1
24	44879	904055	Mazacia skrutka	0.02	1	52	161061	905024	Ozubené dvojkolo	0.25	1
25	410537	904249	Zátka	0.01	1						

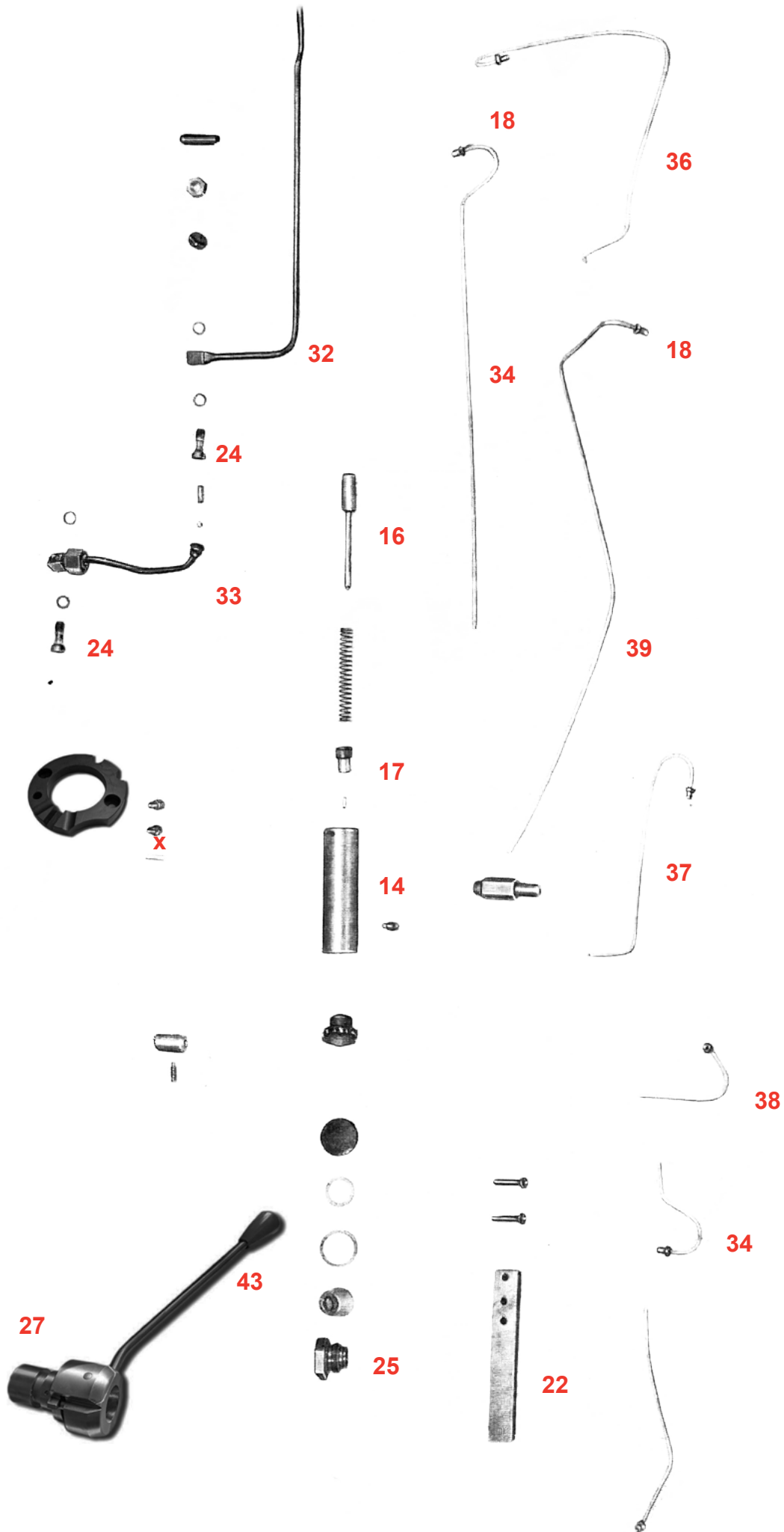

1	2	3	4	5	6
53	200026	905027	Šnekové kolo	0.34	1
54	252867	905034	Príruba	0.65	1
55	330257	905061	Páka	0.33	1
56	VK 2005	905053	Ustavovacia skrutka	0.10	2
57	360239	905056	Gombík rukoväte	1.35	1
58	VK 2007	905061	Vedenie	0.09	1
59	VK 2004	905016	Čap	0.10	1
60	310075	904045	Čap	0.003	1
61	160714	904022	Ozubené kolo	0.80	1
62	440280	904068	Matica	0.30	1
63	360140	905055	Rukoväť	0.37	1
64	280055	904040	Nónius metrický 0-25 mm	0.25	1
66		905014	Čap	0.30	1
67		900012	Čap + rukoväť Ø12	0.05	1
68		904029	Bronzové puzdro Ø26	0.10	1
69		904030	Bronzové puzdro Ø22	0.10	1
Štítky					
65	807040	4 04 16 1007		0.5	2

2.

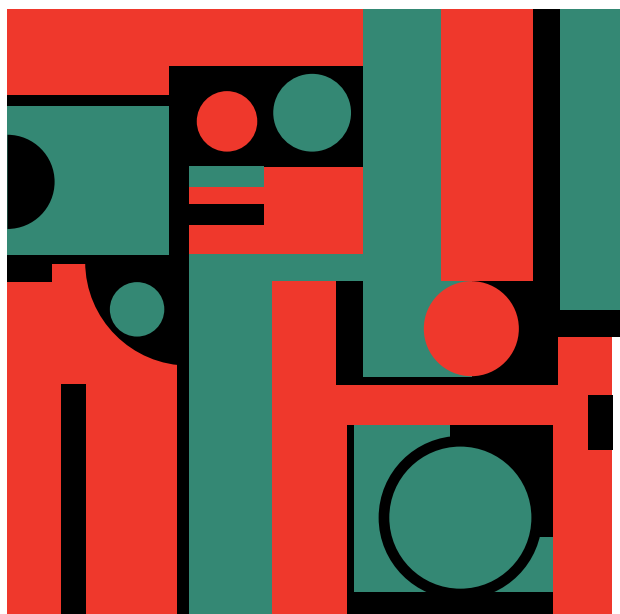

SANE - SUPORTY 906000

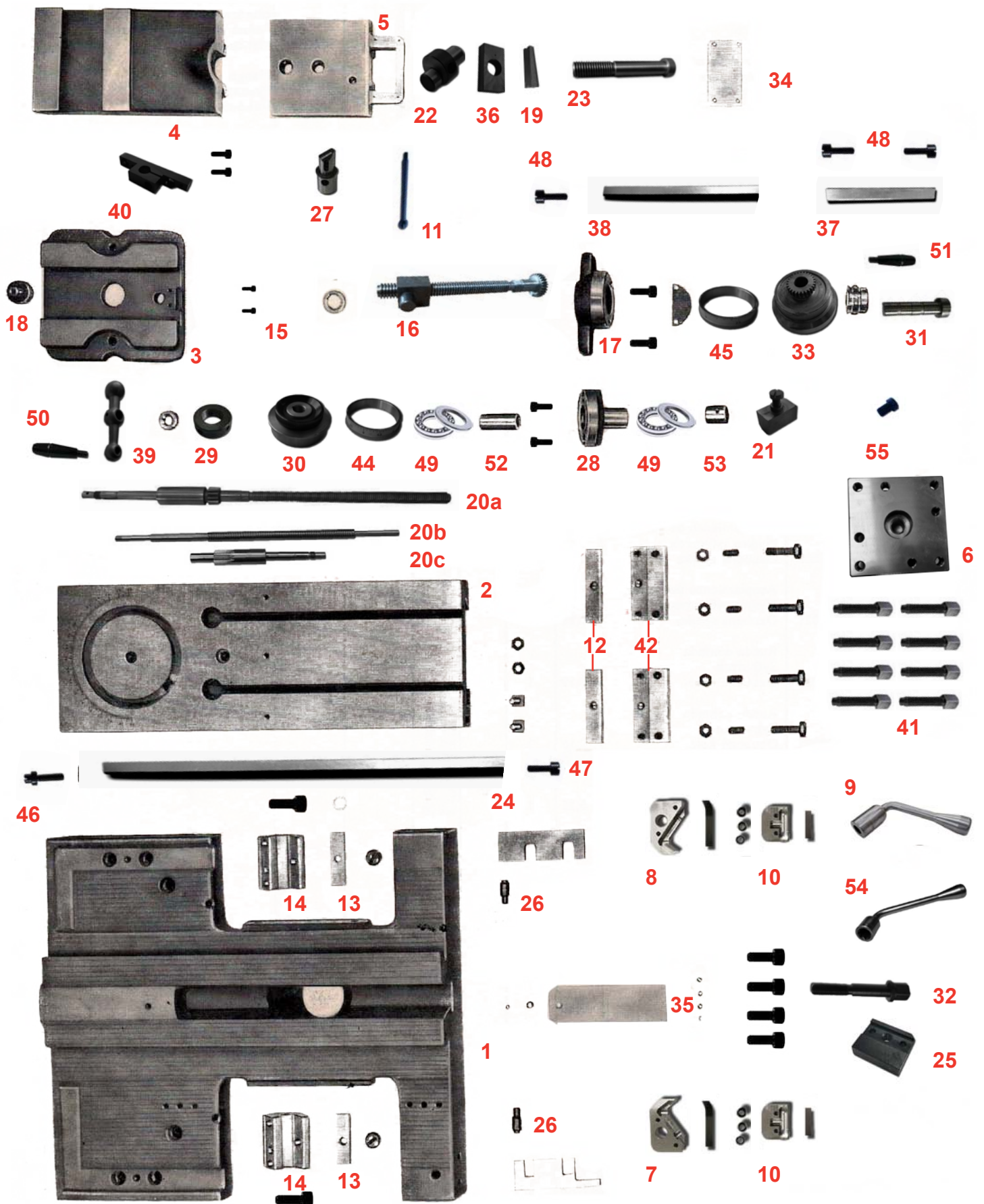

1	2	3	4	5	6	1	2	3	4	5	6
Poradové číslo	Číslo výkresu	Bežné číslo	Názov	Váha / ks (kg)	Počet ks						
						23	410423	906049	Skrutka držiaku	0.15	1
						24	340562	906036	Klinová lišta	0.88	1
1	010133	906001	Teleso	47.00	1	25	VK 2079	906035	Príložka (brzda suportu)	0.40	1
2	030397	906002	Sane suportu	19.00	1	26	310099	906031	Nárazník	0.06	2
3	5003239	906265	Vedenie suportu	7.22	1	27	250552	906026	Puzdro a západka	0.11	1
4	032409	906005	Križový suport	3.70	1	28	250550	906024	Ložisko	0.57	1
5	0502001	906008	Podložka noža	1.02	1	29	220109	906020	Excentrický krúžok	0.21	1
6	033217	906074	Nožová hlava	3.04	1	30	210109	906018	Unášač deliaceho krúžku	0.41	1
7	071133	906010	Stierač	0.06	1	31	VK 2140	906016	Čap	0.12	1
8	071132	906009	Stierač	0.06	1	32		906100	Skrutka brzdy	0.10	1
9	5030326	906314	Páka	0.47	1	33	VK 2138	906017	Koleso	0.80	1
10	071134	906011	Stierač	0.05	2	34	061542	906014	Viečko	0.07	1
11	360176	906042	Rukoväť	0.05	1	35	071136	906013	Viečko	0.08	1
12	VK 1910	906041	Stierač	0.001	1	36	370023	906046	Klzátko	0.08	1
13	340566	906040	Vložka	0.08	1	37	340564	906038	Lišta	0.28	1
14	340565	906039	Prídržná lišta	0.62	2	38	340563	906037	Lišta	0.30	1
15	450246	906063	Matica	0.06	1	39	361096	906044	Kľuka ručná	0.28	1
16	440053	906047	Matica + skrutka	0.42	2	40	351730	906072	Držiak predný	0.22	1
17	030399	904004	Ložisko	1.20	1	41		900912	Skrutka nožovej hlavy M12		8
18	5011691	906266	Čap	0.07	1	42	VK 1911	906034	Lišta zadná	2.92	2
19	470125	906065	Klin klzátko	0.02	1	43	220110	906021	Excentrický krúžok	0.33	1
20a	400060	906059	Skrutka priečných saní	0.90	1	44		906023	Deliaci krúžok - nónius - priečný - 0-6 mm	0.2	1
20b		942039	Priečna skrutka saní s kuželovým pravítkom	0.75	1	45		906030	Deliaci krúžok - nónius - pomocný - 0-3 mm	0.2	1
20c		942014	Predný diel priečnej skrutky s kuželovým pravítkom	0.40	1	46		906500	Skrutka kl. lišty prieč. saní - predná	0.05	1
21	440052	906060	Matica skrutky priečných saní	0.08	1	47		906501	Skrutka kl. lišty prieč. saní - zadná	0.05	1
22	220108	906019	Excenter	0.08	1						

1	2	3	4	5	6
48		906502	Skrutka klinovej lišty nožového suportu	0.05	2
49			Axiálne ložisko 51102	0.05	2
50		900008	Rukoväť ku kolečku Ø8 mm	0.05	1
51		900006	Rukoväť ku kolečku Ø6 mm	0.05	2
52		906022	Puzdro	0.15	1
53		906023	Puzdro	0.10	1
54		900950	Kľuč skrutky nožovej hlavy	0.47	1
55		906503	Zaisťovacia skrutka matice pričného suportu	0.05	1



NORTONOVÁ SKRIŇA 903000

1	2	3	4	5	6	1	2	3	4	5	6
Poradové číslo	Číslo výkresu	Bežné číslo	Názov	Váha / ks (kg)	Počet ks						
						25	110761	903044	Hriadeľ	1.07	1
						26	140276	903045	Čap	0.05	1
						27	110762	903046	Hriadeľ V - ľavý	0.46	1
1	30332	903018	Lýra	1.92	1	28	160673	903047	Hriadeľ II s pastorkom	0.45	1
2	30879	903006	Teleso čerpadla	1.20	1	29	160674	903048	Hriadeľ IV s ozubením	1.79	1
3	50173	903012	Presúvač - A	0.26	1	30	161232	903049	Výmenné kolo	0.64	2 z=24
4	50174	903013	Presúvač - B	0.30	1	31	161233	903050	Výmenné kolo	0.94	1 z=48
5	050175	903014	Presúvač - C	0.25	1	32	161234	903050	Výmenné kolo	0.94	1 z=60
6	050176	903015	Presúvač - D	3.00	1	33	161235	903052	Výmenné kolo	1.10	1 z=71
7	050177	903016	Presúvač - E	0.30	1	34	161236	903053	Výmenné kolo	1.31	1 z=131
8	050178	903017	Presúvač - F	0.25	1	35	160680	903054	Ozubené kolo - hriadeľ I	0.10	1 z=18
9	VK 1408	903019	Pružina	0.01	1	36	160681	903055	Ozubené kolo - hriadeľ II	0.40	1 z=45
10	080225	903023	Veko hriadeľ II	0.15	1	37	160682	903056	Dvojkolo - hriadeľ II	0.34	1 z=25/35
11	080226	903024	Veko hriadeľ III - ľavé	0.16	1	38	160683	903057	Dvojkolo - hriadeľ III	0.22	1 z=18/28
12	080228	903026	Veko hriadeľ III - pravé	0.16	1	39	160684	903058	Dvojkolo	0.77	1 z=40/48
13	080229	903027	Zátka	0.10	1	40	160685	903059	Ozubené kolo - hriadeľ III	0.20	1 z=24
14	VK 263	903029	Kolík	0.04	1	41	160686	903060	Ozubené kolo - hriadeľ IV	0.20	1 z=24
15	080232	903030	Zátka - pravá	0.03	1	42	160687	903061	Ozubené kolo - hriadeľ II	0.22	1 z=26
16	413450	903031	Zátka - filter	0.13	1	43	160688	903062	Ozubené kolo - hriadeľ III	0.16	1 z=29
17	111594	903032	Hriadeľ - pravý	0.61	1	44	160689	903063	Ozubené kolo - hriadeľ II	0.20	1 z=20
18	1100 5112	903034	Hriadeľ I	0.23	1	45	160690	903064	Ozubené kolo	0.24	1 z=28
19	110619	903035	Hriadeľ II - stredný	0.90	1						
20	110259	903037	Hriadeľ III - ľavý	0.56	1						
21	110260	903038	Hriadeľ III - pravý	0.45	1						
22	VK 1981	903039	Hriadeľ IV - pravý	0.85	1						
23	111567	903042	Hriadeľ presúvača	1.42	1						
24	110265	903043	Hriadeľ VII	0.45	1						

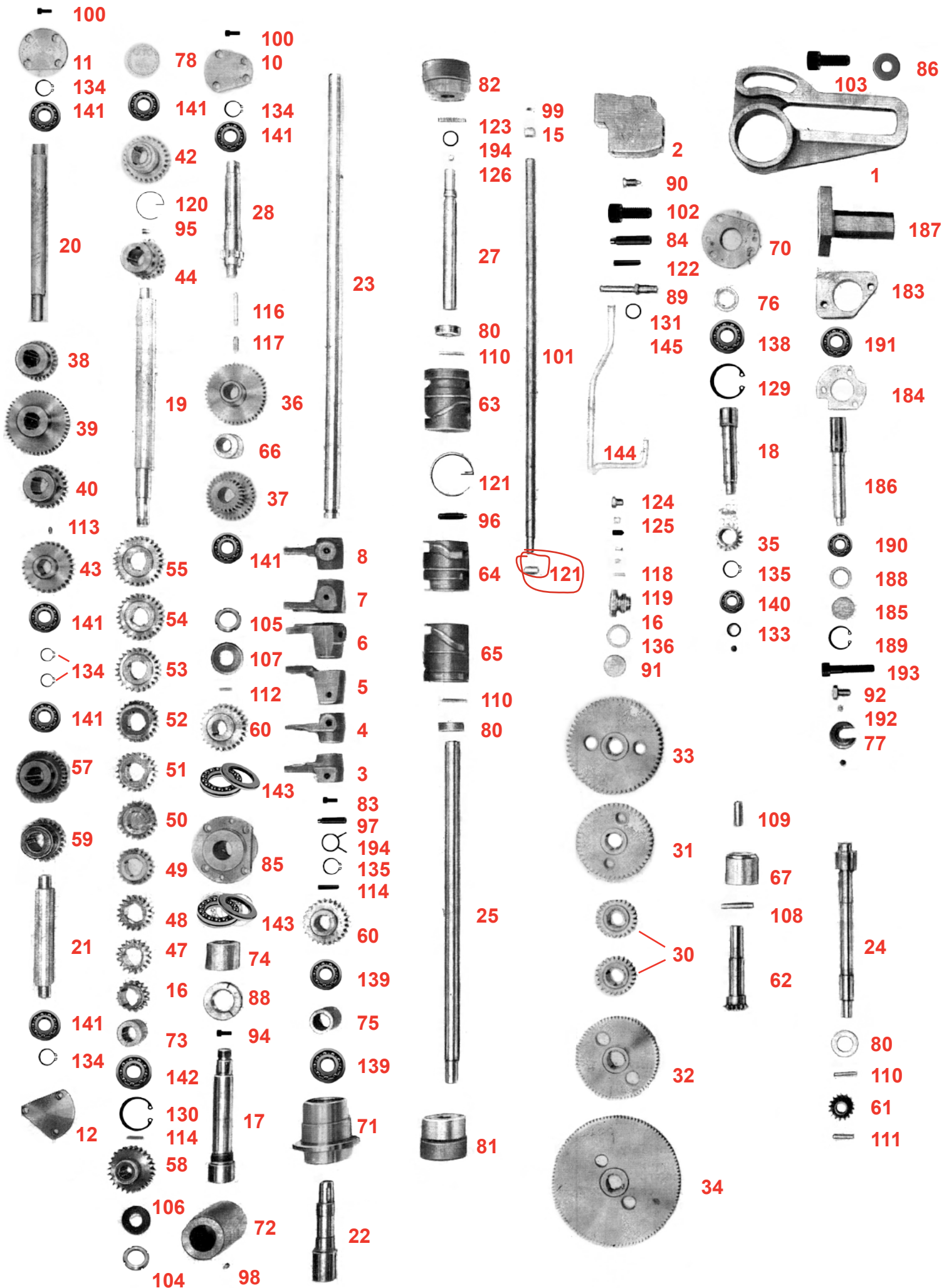

1	2	3	4	5	6	1	2	3	4	5	6
46	160691	903065	Ozubené kolo - hriadeľ II	0.08	1 z=16	68	VK 1312	903091	Držiak štítkov	0.10	1
47	160692	903066	Ozubené kolo	0.08	1 z=18	69	VK 1313	903092	Držiak štítkov	0.10	1
48	160693	903067	Ozubené kolo	0.08	1 z=19	70	250462	903095	Puzdro ložiska	0.26	1
49	160694	903068	Ozubené kolo	0.10	1 z=20	71	250466	903093	Puzdro ťažného hriadeľa	0.97	1
50	160695	903069	Ozubené kolo	0.12	1 z=21	72	253119	903100	Puzdro	0.45	1
51	160696	903070	Ozubené kolo	0.14	1 z=22	73	261375	903101	Krúžok rozperný	0.14	1
52	160697	903071	Ozubené kolo	0.15	1 z=23	74	263294	903102	Krúžok operný	0.28	1
53	160698	903072	Ozubené kolo	0.16	1 z=24	75	260577	903103	Puzdro rozperné	0.08	1
54	160699	903073	Ozubené kolo - hriadeľ II	0.20	1 z=26	76	260580	903107	Krúžok odstrekový	0.06	2
55	160700	903074	Ozubené kolo	0.22	1 z=28	77	VK 1672	903108	Podložka	0.02	2
56	160701	903075	Ozubené kolo - hriadeľ IV	0.28	1 z=27	78	260582	903109	Rozperné puzdro	0.05	1
57	160702	703076	Dvojkoľo	0.45	1 z=23/35	79	260583	903110	Rozperné puzdro	0.02	1
58	160703	903077	Ozubené kolo - hriadeľ II	0.20	1 z=26	80	2601376	903111	Krúžok stavací	0.05	3
59	160704	903078	Ozubené kolo - hriadeľ III	0.18	1 z=23	81	280149A	903115	Hlavica - pravá	1.07	1
60	160705	903079	Ozubené kolo - hriadeľ II, IV	0.19	2 z=26	82	280150	9023117	Hlavica - ľavá	0.88	1
61	180448	903082	Ozubené kolo kuželové	0.08	1	83	310066	903118	Čap presúvací	0.01	6
62	150557	903083	Pastorok kuželový	0.25	1	84	310212	903119	Piest	0.07	1
63	220091	903086	Bubon presúvača	1.18	1	85	VK 2167	903122	Puzdro vodiacej skrutky	2.39	1
64	220092	903087	Bubon presúvača	0.98	1	86	320254	903125	Podložka	0.02	1
65	220093	903088	Bubon presúvača	1.18	1	87	VK 1622	903134	Skrutka M10x70	0.04	1
66	220094	903089	Excenter	0.15	1	88	450366	903136	Matica zaistovacia	0.14	1
67	220491	903090	Excenter	0.40	1	89	410956	903139	Skrutka	0.03	1
						90	410957	903140	Zátka	0.04	1
						91	540083	903148	Filter	0.04	1
						101	560097	903146	Trubka	0.29	1
						104	Ob50322	903333	Matica	0.08	1
						105	Ob50178	5 04 30 1379	Matica	0.08	1

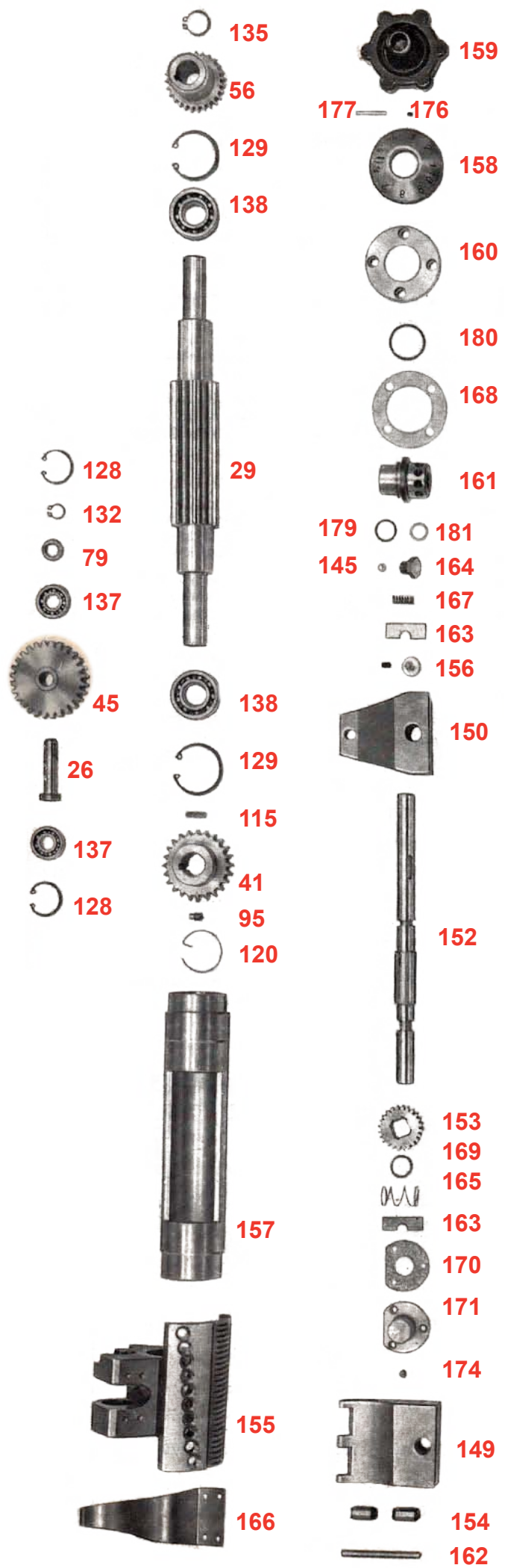

1	2	3	4	5	6	1	2	3	4	5	6
106	Ob50231	903338	Poistná podložka	0.01	1	170	5057157	903546	Tesnenie	0.01	1
107	Ob50232	903339	Poistná podložka	0.01	1	171	080227	903603	Věčko	0.15	1
127	ČSN 02 7496	903381	Olejoznak M24x15		2	185	081992	903604	Zátka	0.01	1
131	VK 237	903389	Tesniaci krúžok	0.01	1	186	110511	903606	Hriadeľ výmenných kôl	0.35	1
136	VK 238	903394	Tesniaci krúžok	0.01	1	187	253102	903608	Puzdro	0.70	1
144	561154	903407	Trubka výtoková	0.01	1	188	260581	903610	Krúžok rozperný	0.03	1
146	5003109	903474	Teleso skrine	44.00	1	189	570059	908585	Štítok	0.08	1
147	5006088	903477	Veko	11.75	1	190	5057077	900032	Štítok	0.02	1
148	5008163	803479	Veko	1.64	1	191	5057076	900031	Štítok	0.07	1
149	5005139	903486	Presúvač	0.98	1	192	5057075	900030	Štítok	0.07	1
150	5005140	903587	Presúvač	0.38	1	193	5057072	900027	Štítok	0.05	1
151	5060160	903490	Kryt výmenných kôl	5.85	1						
152	5011594	903503	Hriadeľ	0.35	1						
153	5016285	903511	Ozubené kolo	0.08	1						
154	5022124	903512	Kladka	0.04	2						
155	5022089	903513	Presúvací segment	1.55	1						
156	5022091	903515	Západka	0.01	1						
157	5024094	903518	Valec	1.38	1						
158	5028049	903520	Stupnica	0.15	1						
159	5030212	903523	Ručné kolo	0.80							
160	2030213	903527	Věčko	0.17	1						
161	5030214	903525	Náboj	0.17	1						
162	5046041	903530	Kolík	0.10	1						
163	5052078	903533	Vložka	0.01	1						
164	5041150	903535	Zátka	0.02	1						
168	5052123	903545	Tesnenie	0.01	1						
169	5052123	903545	Podložka	0.01	1						



151



148



193



189



190

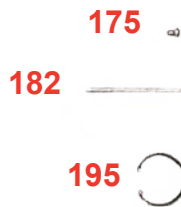

175

182

195



127

13



178

173

87

172

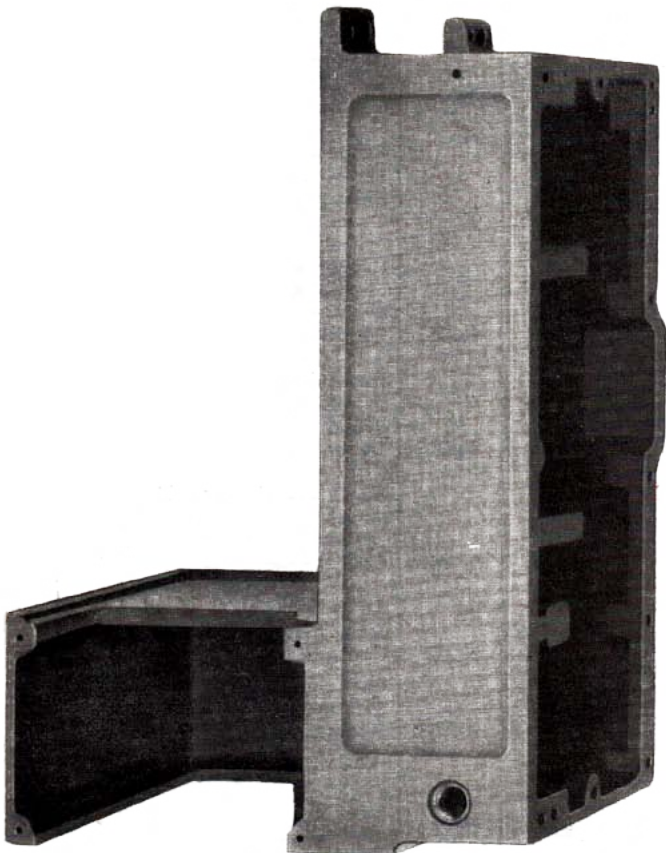

146



147



68



192



191



69



93



RÝCHLOSTNÁ SKRIŇA 902000

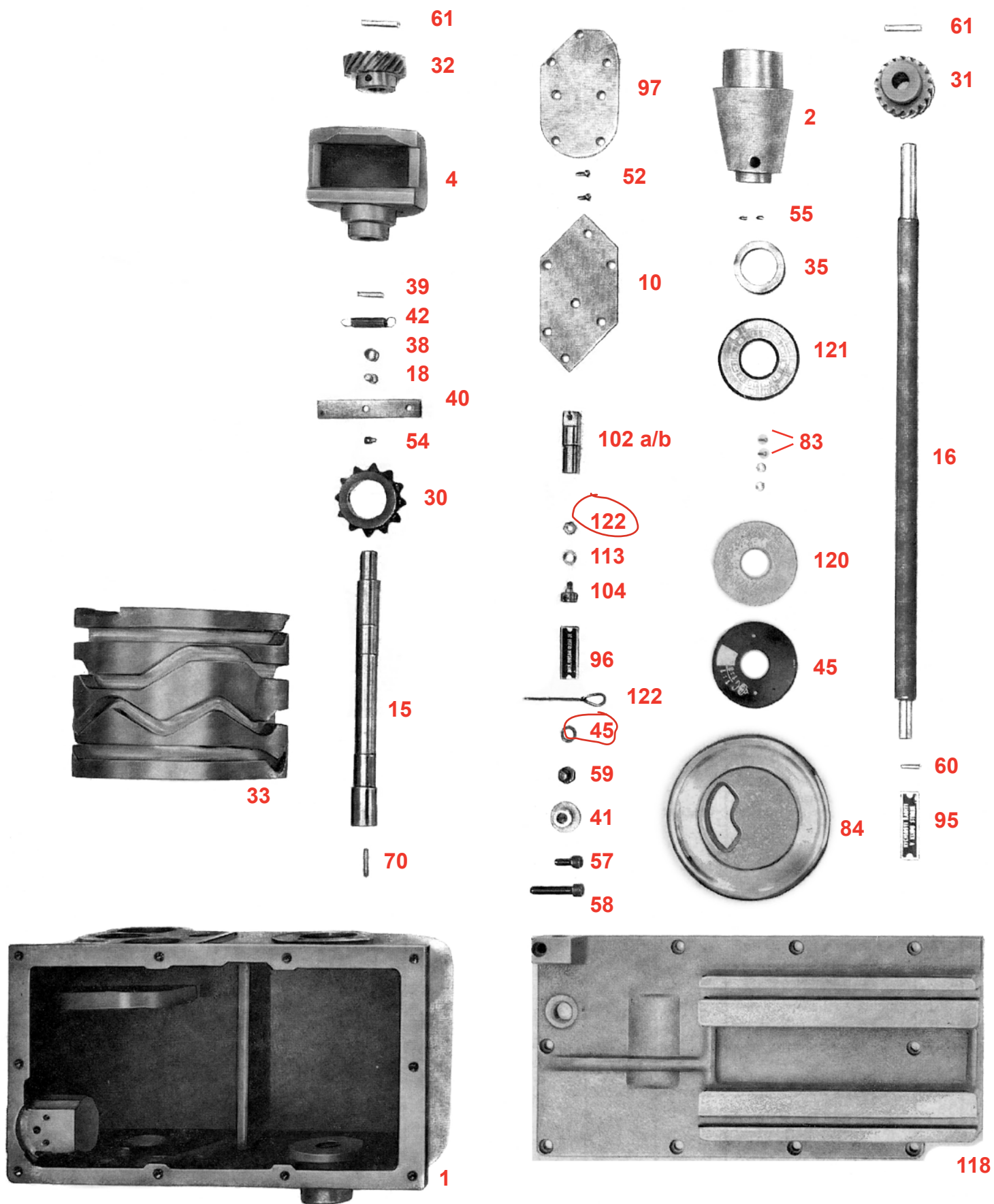

1	2	3	4	5	6	1	2	3	4	5	6	
Poradové číslo	Číslo výkresu	Bežné číslo	Názov	Váha / ks (kg)	Počet ks							
						25	160807	902036	Ozubené kolo	0.15	1 z=17	
						26	160808	902037	Ozubené kolo - hriadeľ III	0.53	1 z=22	
1	010602	902001	Teleso skrine	29.05	1	27	160809	902038	Ozubené kolo	0.22	1 z=28	
2	030404	902002	Konzola	2.50	1	28	160810	902039	Ozubené kolo	0.56	1 z=33	
3	030405	902003	Ložisko príruby hriadeľ III	2.85	1	29	160811	902040	Ozubené kolo	0.63	1 z=38	
4	030406	902004	Ložisko príruby hriadeľ IV	3.38	1	30	160812	902041	Rohadka - hriadeľ VI	0.30	1	
5	031590	902231	Čerpadlo kompletné	1.5	1	31	200053	902042	Šnekové kolo	0.60	1	
6	050204	902006	Presúvač - A	0.48	1	32	200271	902043	Šnekové kolo	0.64	1	
7	050205	902007	Presúvač - B	0.48	1	33	220111	902044	Valec presúvača	15.92	1	
8	050206	902008	Presúvač - C	0.48	1	34	220112	902045	Vačka	0.22	1	
9	050207	902009	Presúvač - D	0.60	1	35	VK 2466	902046	Príruba	0.34	1	
10	071153	902011	Veko	0.64	1	36	260699	902049	Krúžok rozperný	0.01	1	
11	110609	902017	Hriadeľ I s pastorkom	1.55	1	37	260700	902050	Krúžok rozperný	0.02	1	
12	110321	902018	Hriadeľ II s pastorkom	1.00	1	38	300015	902052	Kladka	0.03	5	
13	110322	902019	Hriadeľ III	1.88	1	39	310101	902053	Čap	0.02	1	
14	110323	902020	Hriadeľ presúvača IV, V	0.66	1	40	331143	902052	Páka západky	0.14	1	
15	111595	902021	Hriadeľ valca VI	1.10	1	41	412425	902062	Zátka	0.15	1	
16	110325	902022	Hriadeľ presúvača VII	2.16	1	42	510185	902065	Pružina	0.05	1	
17	140392	902023	Čap	0.03	4	43	44	VK 1231	902064	Skrutkovanie	0.05	1
18	140393	902024	Čap	0.02	1	45	540186	902068	Kryt štítku	0.04	1	
20	160802	902031	Ozubené kolo - hriadeľ I	0.79	1 z=34	46	5601828	902066	Trubka	0.01	1	
21	160802	902032	Ozubené kolo - hriadeľ	0.78	1 z=37	47	560129	902070	Trubka	0.04	1	
22	160804	902033	Ozubené kolo - hriadeľ II	1.25	1 z=47	48	560130	902071	Trubka	0.01	1	
23	160805	802034	Ozubené kolo	0.48	1 z=23	49	64	260819	902134	Príložka	0.01	1
24	160806	902035	Ozubené kolo	0.37	1 z=17	65	VK 240	902136	Tesniaci krúžok	0.01	1	
						80	520085	902159	Poistná podložka	0.04	1	

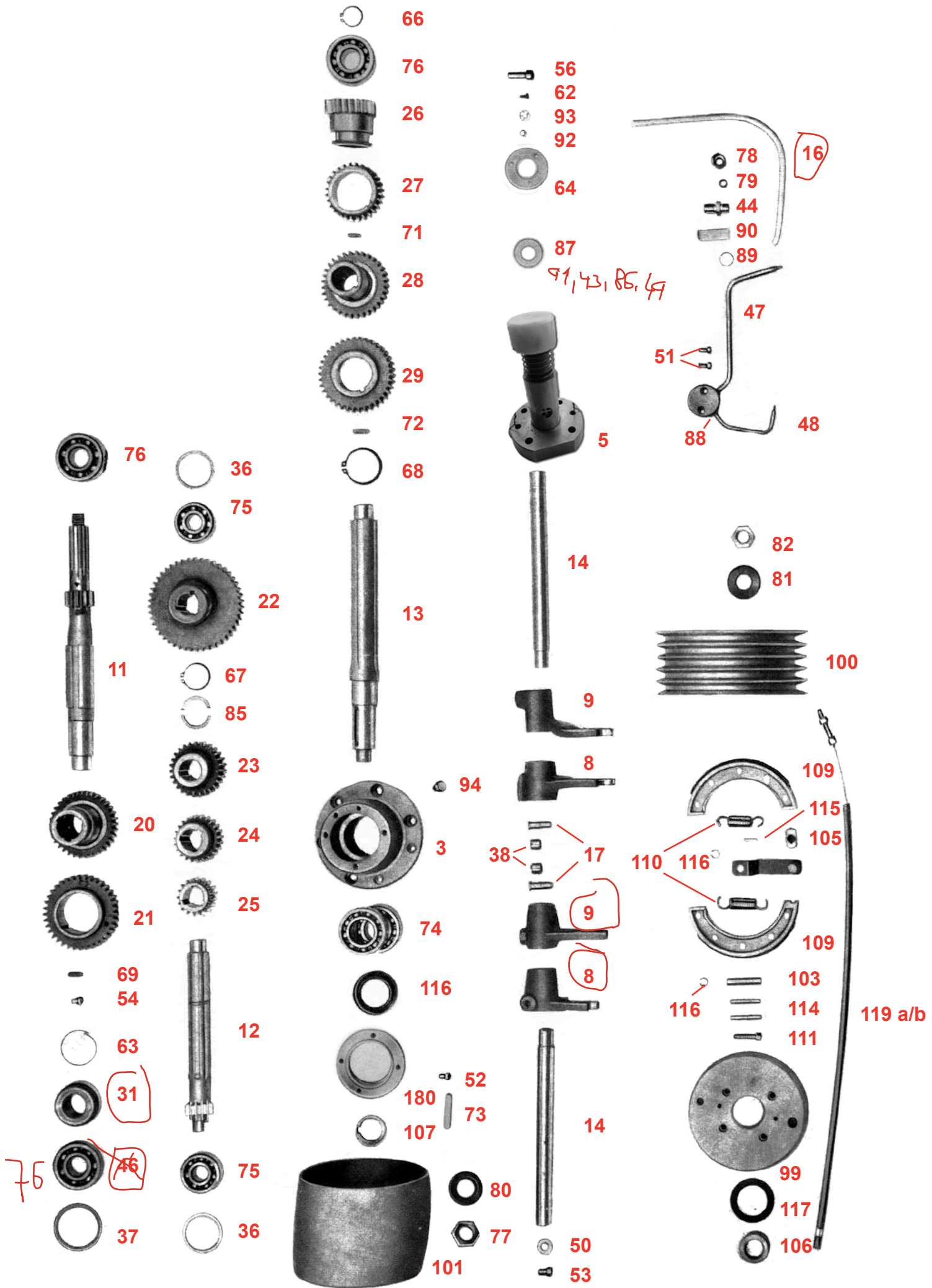

Rýchlostná skriňa 902000

1	2	3	4	5	6	1	2	3	4	5	6
81	52086	902160	Poistná podložka	0.04	1	95	970052	808580	Štítok	0.01	1
84	360272	902172	Radiace kolo	3.00	1	121	5057071	900026	Štítok	0.01	1
85	264058	902177	Krúžok	0.05	1						
86	321192	902187	Podložka	0.02	1						
87	321259	902180	Hlavička rozdelovača	0.18	1						
88	251639	902180	Puzdro	0.18	1						
89	540272	902183	Sítko	0.01	1						
90	540430	902184	Vložka	0.02	1						
91	5006095	902254	Veko	0.58	1						
92	5008176	902256	Rameno	0.10	1						
93	5009147	902260	Príruba	2.50	1						
94	5009148	902261	Remenica klinová	3.90	1 60 Hz						
95	5009153	902262	Remenica plochá	3.32	1 60Hz						
96	5011424	902264.6	Čap M6	0.23	1						
97	5011424	90226.7	Čap M7	0.23	1						
98	5011425	902265	Čap	0.25	1						
99	5011434	902268	Čap	0.03	1						
100	5022094	902273	Brzdový kotúč	0.05	1						
101	5026338	902276	Krúžok operný	0.06	1						
102	5026339	902277	Krúžok operný	0.02	1						
103	5030321	902279	Veko	0.25	1						
104	01-4027	902294	Čelusť úplná	0.20	2						
105	5051012	902295	Pružina	0.01	2						
106	5003244	902342	Veko vrchné	18.00	1						
107	60173	902300.6	Bowden M6	0.10	1						
108	60173	902300.7	Bowden M7	0.10	1						
109	VK 807	902105	Olejoznak	0.01	1						



ŠTÍTKY

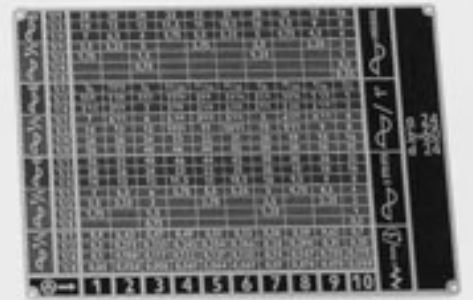
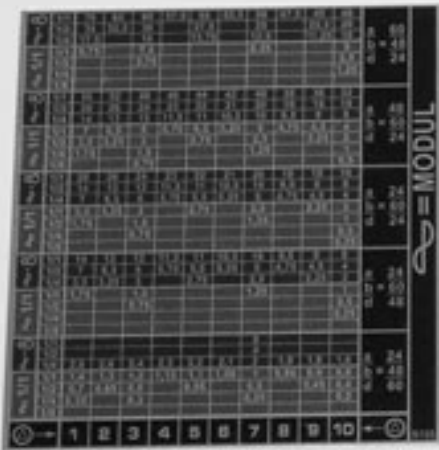
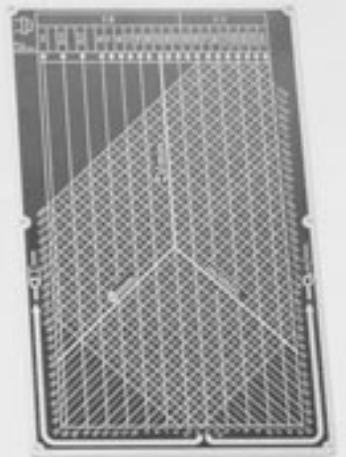

SV 18 RA



RYCHLOSTI RADI
V KEUDE STROJA

